

GU10

Features:

LED equivalent replacement to 35W halogen.
Uses: art galleries, architectural lighting, display case accent, hospitality, residential, landscape, and track lighting.

Aluminium alloy & Special lens

Dimmable

UL Listed



24/7 Commercial Warranty

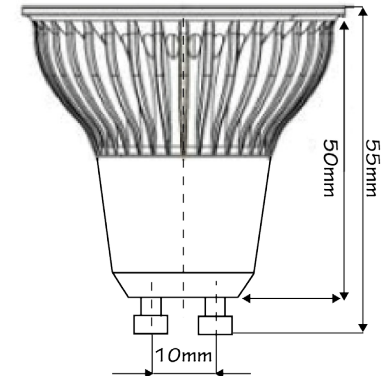
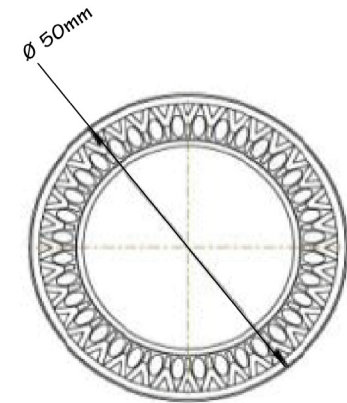

Electrical Optical Characteristics

Model	Beam Angles	Chip	Watts	Volts	Lumens	Colors
EFL-GU10-3x3-XPE	30° · 45° · 60°	CreeXP-E	5W	120V	WW: 235 · CW: 280	2700K · 3000K CCT
EFL-GU10-3X3-XPG	30° · 45° · 60°	CreeXP-G	5w	120V	WW: 375 · CW: 480	2700K · 3000K CCT